



# Industrial Water Reuse Systems



- Treatability Testing & Tailored System Design
- On-Site Pilot Testing
- System Installation and Startup
- Advanced Automation & Remote Monitoring
- Operator Training
- Technical Support
- Maintenance and Replacement Parts
- Chemicals and Consumable Sales

ProChem water reuse systems utilize the most effective technology to reclaim and treat wastewater from any industrial process. These innovative and flexible systems integrate seamlessly with your existing treatment system, allowing you to convert what was once wastewater into high-quality process water.



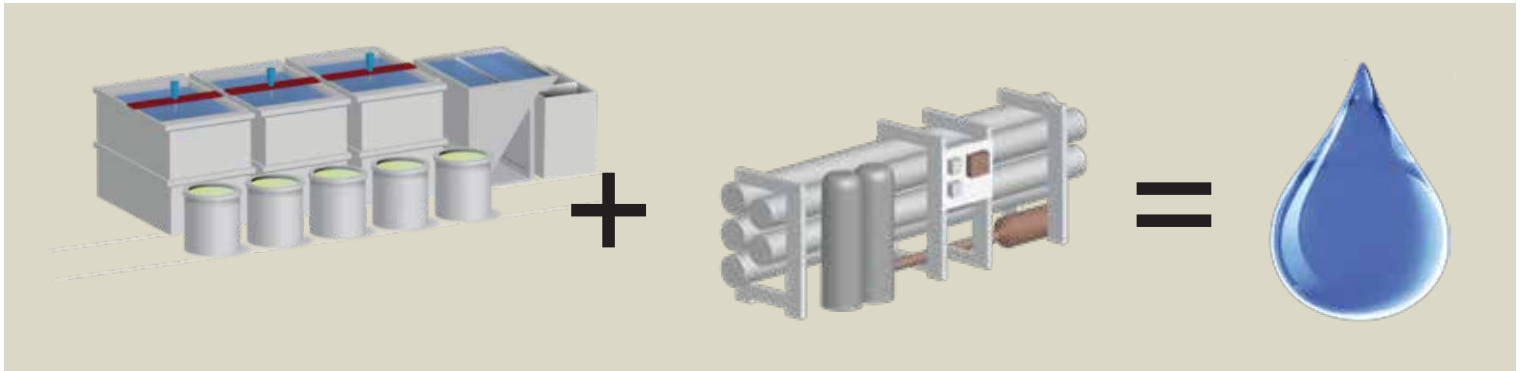

## System Integration

ProChem, Inc. water reuse systems are an end-of-pipe solution, meaning that they are designed to be integrated into your existing wastewater treatment system.



### Water Reuse Technology

Effectively reusing industrial wastewater is a multi-step process, combining the most effective water treatment protocols in a particular order. Our systems utilize the following treatment protocols:

- Physical & chemical treatment \ion-exchange
- Solids removal (filtration, settling, etc.)
- Chemical pretreatment
- Membrane filtration
- Sterilization/microbiological control

### Reuse Applications

Common reuse applications include wastestreams such as: e-coating/powder coating, HVAC, metal finishing (nickel, copper, etc.), oily, power generation, and so on. We will design a reuse system specifically for your unique water.



### High Pressure Reverse Osmosis

HPRO units are used in water reuse systems that require membrane filtration to filter and purify the process water for reuse. When concentrate enters the HPRO unit, high pressure is used to force it through a series of membranes, chosen to filter the specific particles in the water. The particles become trapped in the membrane, allowing the purified water to flow out of the unit.

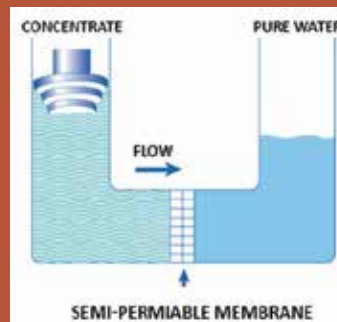

Our engineers and fabricators custom build HPRO units to suit the treatment need as well as the physical space in your facility.



### Real World Results

Our water reuse customers report benefits such as:

- \$90,000 per year savings on the purchase and disposal of water
- 100% environmental compliance
- Lower operating costs (due to automation and monitoring features)
- 100% water reuse (no discharge permit)
- Environmental awards

### Is Reuse Right For You?

- Spend a lot of money on water?
- Pretreat the water before use?
- Process that could use reuse water?
- Operating costs a key player?
- Limited wastewater treatment space?

Visit our website to learn more about how you can be proactive with water stewardship.



[www.prochemwater.com](http://www.prochemwater.com)

[info@prochemwater.com](mailto:info@prochemwater.com)

800.290.2295

